

NEW

04 CHAMELEON POST GLASS SYSTEM

CHAMELEON POST GLASS SYSTEM

60 - 63

04 CHAMELEON POST GLASS SYSTEM



RUBBER Mallet TO BE USED



PRODUCT TO BE GLUED WITH E4054



ASSEMBLY WITH ALLEN KEY



PRODUCT TO BE WELDED



ANTI-CLIMB PRODUCT



SUPER STRONG, HIGH RESISTANT PRODUCT



The Chameleon Post Glass system meets a wide range of architectural requirements, with a design focused around glass panels which fit into stainless steel columns. This ensures a balustrade system which is characterised by its strength and durability.

The glass panels can be customised with tints, colours and shapes, while different finishes are also available for the posts. The excellent performance properties makes Chameleon an ideal option for both private and public applications.

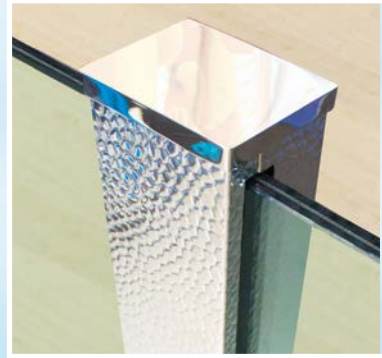

NEW

CHAMELEON POST GLASS SYSTEM

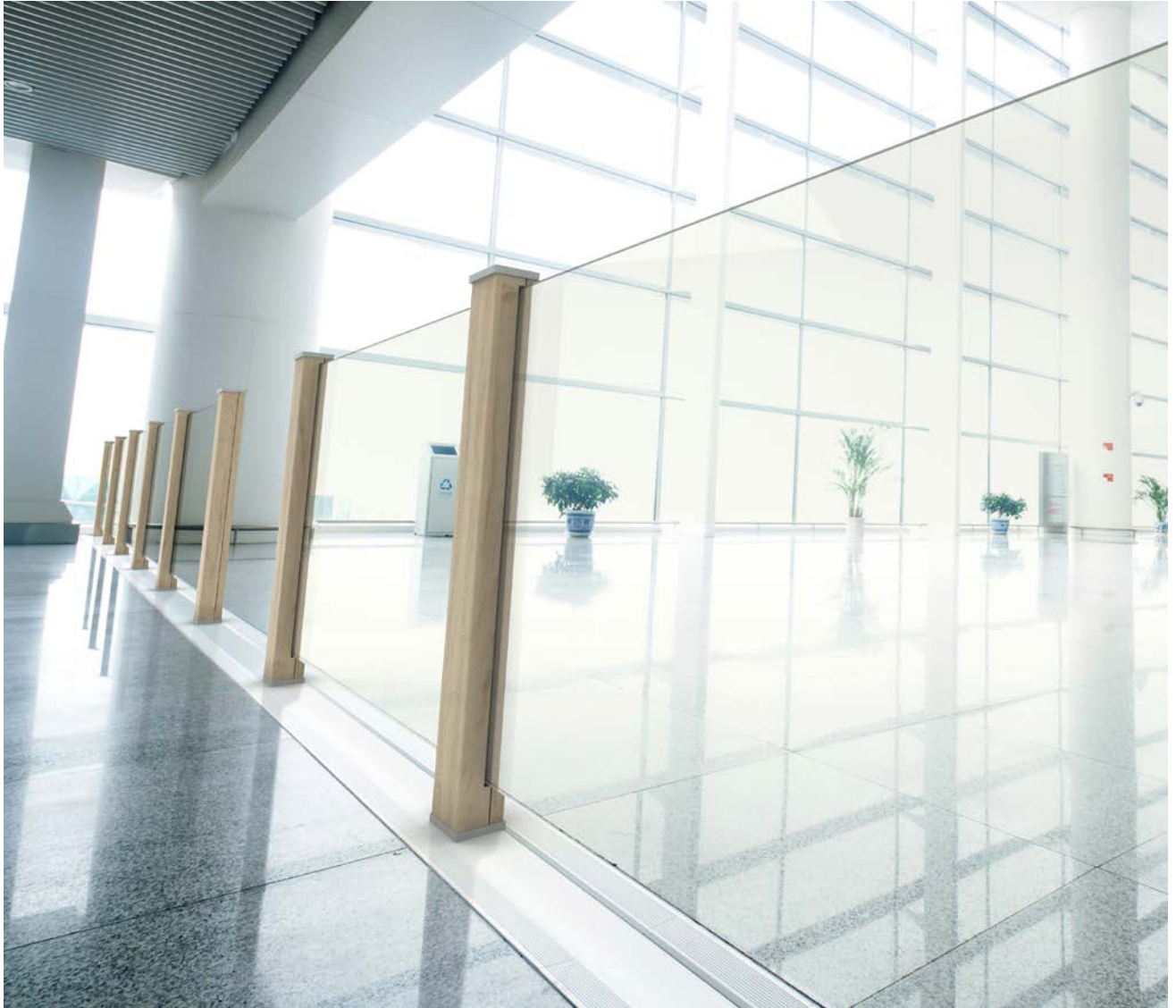

04 CHAMELEON POST GLASS SYSTEM

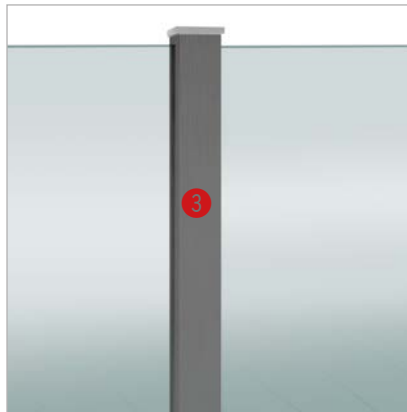
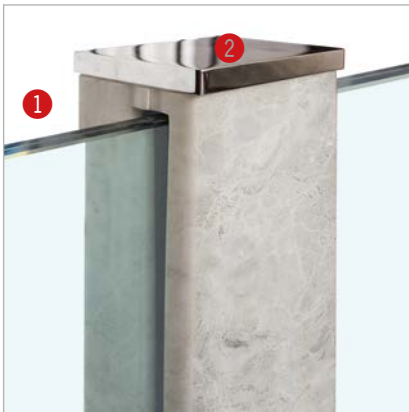

- 1 Simplified installation of glass infill thanks to the fixing system hidden within the structure.
- 2 Base and top closures accommodate and incorporate custom covers.
- 3 If unspecified, the Chameleon posts are supplied in the mild steel raw finish version.

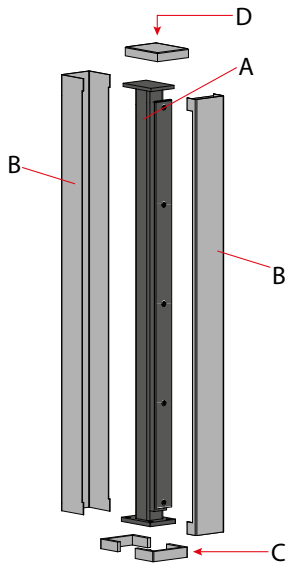

COMPONENTS INCLUDED IN THE KIT

- A)** 1 Galvanised mild steel structural post
- B)** 2 Customisable covers in material and finishing
- C)** 1 Lower closing cap in stainless steel mirror polished
- D)** 1 Upper closing cap in mirror polished stainless steel

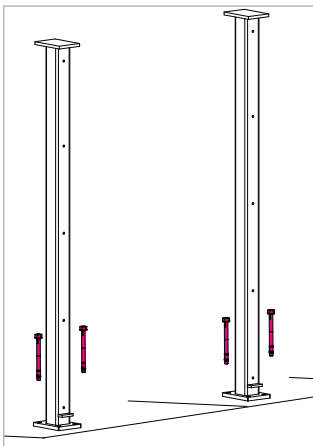
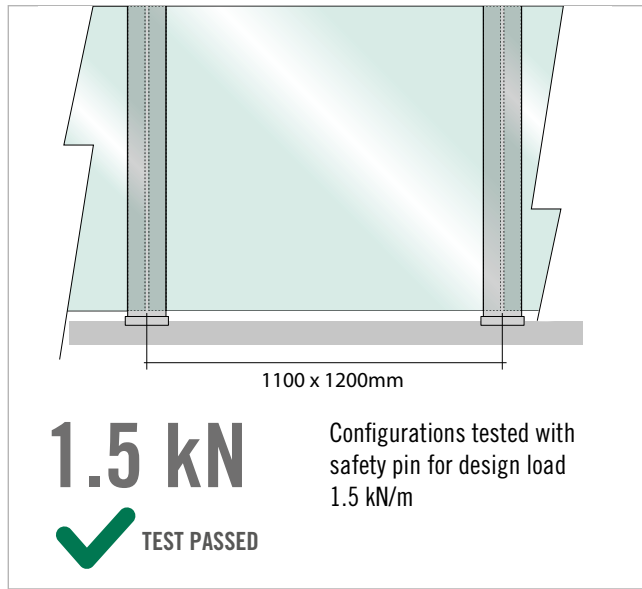

• Mount the structural load-bearing element at the desired pitch.

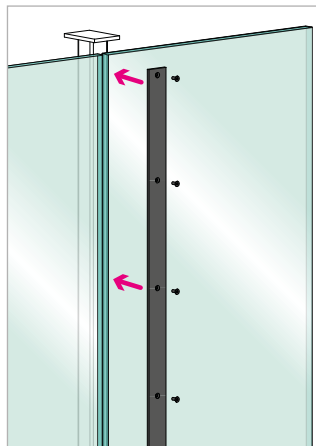

• Apply the glass and secure with the appropriate flat fixing brackets with gaskets.

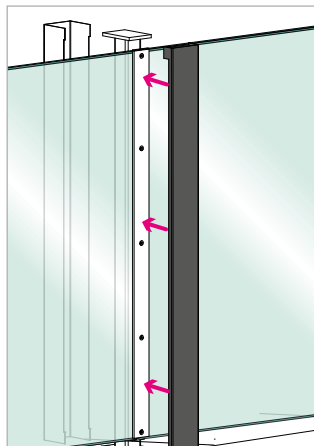

• Apply the covers of the chosen material and finish and attach to the previously mounted structure.

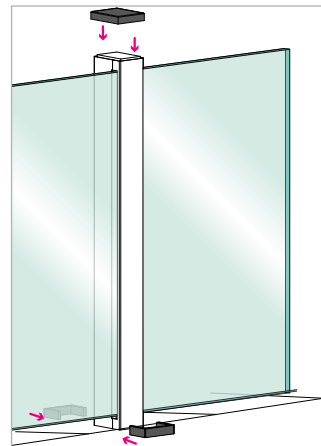

• Apply the upper and lower caps.



1 Example of a Corian cover.



2 Customisation in dark beechwood.



3 Copper green acid-etched steel cover. Also available in brass, copper, corten or other metals.

CHAMELEON POST

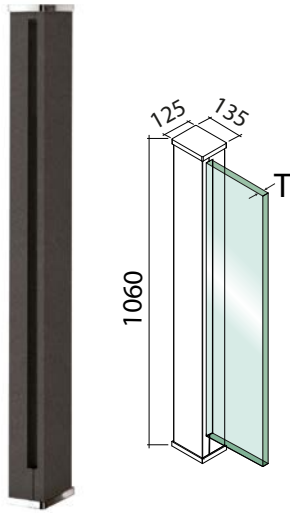

T = from 10 to 17.52mm

COVER IRON ZINC	COVER FINISH
I2000400	Raw

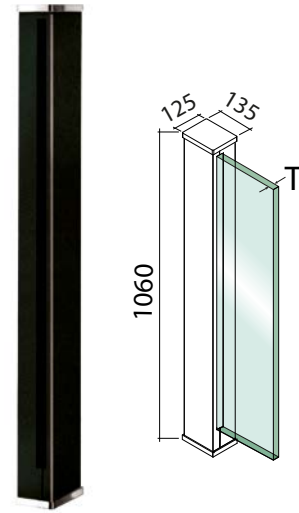

T = from 10 to 17.52mm

COVER IRON ZINC	COVER FINISH
V2000430	Matt Black RAL 9005

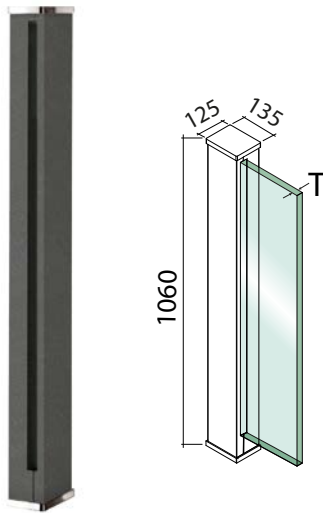

T = from 10 to 17.52mm

COVER IRON ZINC	COVER FINISH
V2000420	Iron RAL 7021

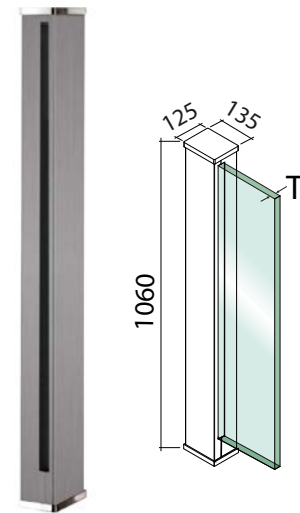

T = from 10 to 17.52mm

COVER AISI304	COVER AISI316	COVER FINISH
E2000440	E2000440316	Satin finish



The Chameleon Post kits consist of:
end caps, supporting structure and cover.

If unspecified, the Chameleon Posts are supplied in the mild steel raw finish version, along with AISI 304 mirror polished accessories.

CHAMELEON POST

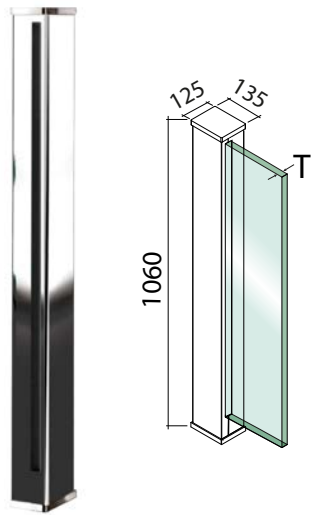

T = from 10 to 17.52mm

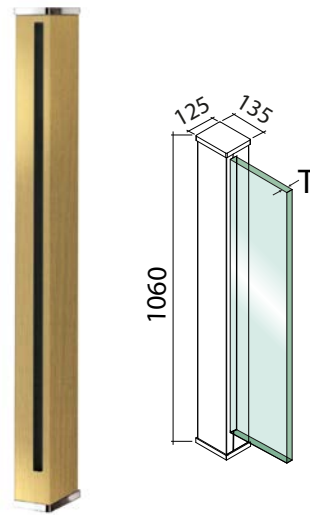

T = from 10 to 17.52mm

COVER AISI316	COVER FINISH
X2000440316	Mirror polished

COVER BRASS	COVER FINISH
E2000410	Satin brass

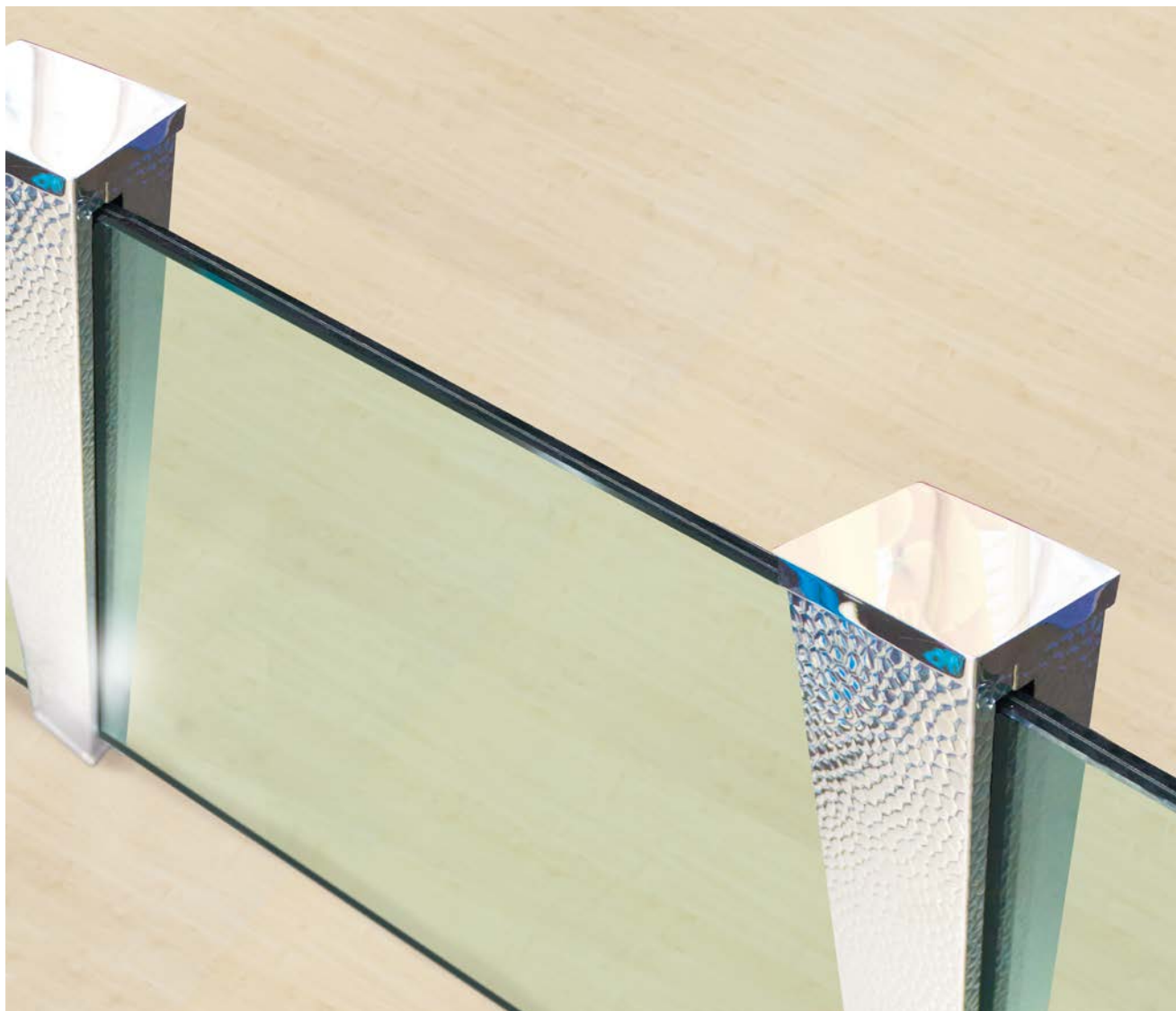

NEW

04 CHAMELEON POST GLASS SYSTEM